

CTP431: Fundamentals of Computer Music

# Delay-based Audio Effects



**Juhan Nam**

# Goal

- Understanding the perception of time delay in comb filters
- The implementation details of delay-based audio effects
  - Delay (Echo)
  - Chorus
  - Flanger effects
- Physical modeling: digital waveguide model

# Introduction

- Types of delay-based audio effect
  - Delay
  - Chorus
  - Flanger
  - Reverberation (this will be covered in the topic of spatial audio)



# Introduction

- Video demos
  - <https://www.youtube.com/watch?v=zmN7fK3fKUE&list=PL081D4BE59AE08F99&index=1>
- Delay
  - <https://www.youtube.com/watch?v=oCJLvtTkDKA>
  - <https://www.youtube.com/watch?v=8r3LzV4BnyM>
- Chorus
  - <https://www.youtube.com/watch?v=z9LiPuVRyU8>
- Flanger
  - <https://www.youtube.com/watch?v=Obnibgewtsw>

# Introduction

- Delay-based effects originated from tape recording
  - Les Paul: innovator in sound production
    - Well-known for “Gibson Les Paul” electric guitar and also developed unique guitar play techniques
    - Doubling/ensemble effects: make rich vocals
    - Delay or Flanging effects



Les Paul

# Comb Filter

- Implemented by circular buffer: move read and write pointers instead of shift all samples in the delayline

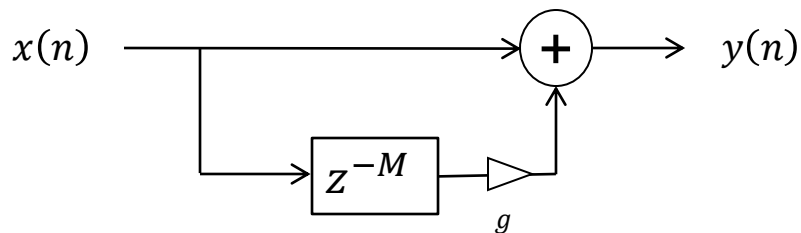

$$y(n) = x(n) + g \cdot x(n - M)$$

FIR Comb Filter

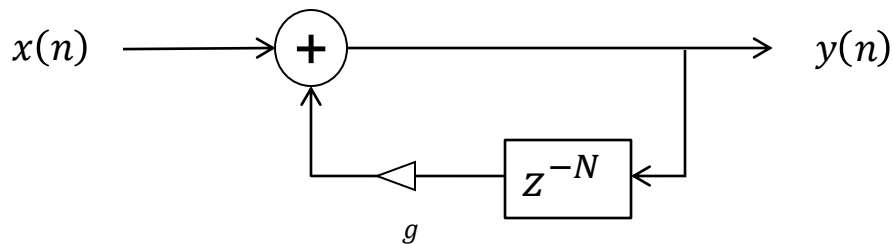

$$y(n) = x(n) + g \cdot y(n - N)$$

IIR Comb Filters

# Comb Filter: Frequency Response

- "Combs" become shaper in the feedback type

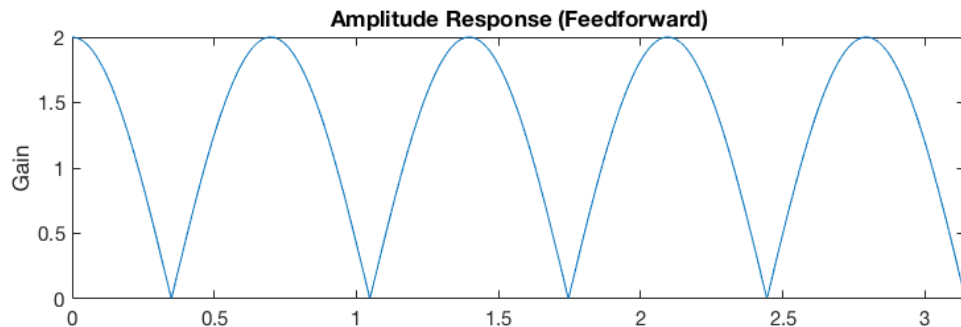

$$y(n) = x(n) + x(n - 8)$$

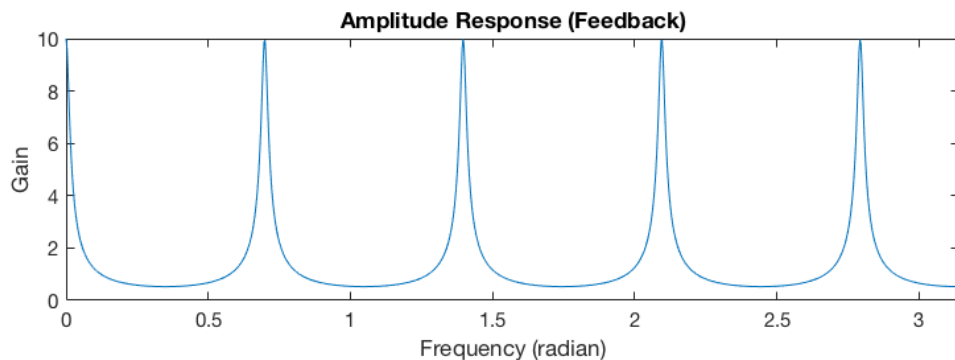

$$y(n) = x(n) + 0.9 \cdot y(n - 8)$$

# Perception of Time Delay

- The 30 Hz transition
  - Given a repeated click sound (e.g. impulse train):
    - If the rate is less than 30Hz, they are perceived as discrete events.
    - As the rate is above 30 Hz, they are perceived as a tone
  - Demo: <https://auditoryneuroscience.com/pitch/range-period-pitch>
- Feedback comb filter:  $y(n) = x(n) + a \cdot y(n - N)$ 
  - If  $N < \frac{F_s}{30}$  ( $F_s$ : sampling rate): change tone of the input sound
    - If  $N$  is large under this condition, it can generate a pitched tone as it models sound propagation and reflection on a string (e.g. Karplus-Strong model)
  - If  $N > \frac{F_s}{30}$  ( $F_s$ : sampling rate): repeat discrete events with gain loss

# Fractional Delay

- Necessary when the length of delay continuously changes
  - Chorus, flanger and other modulations

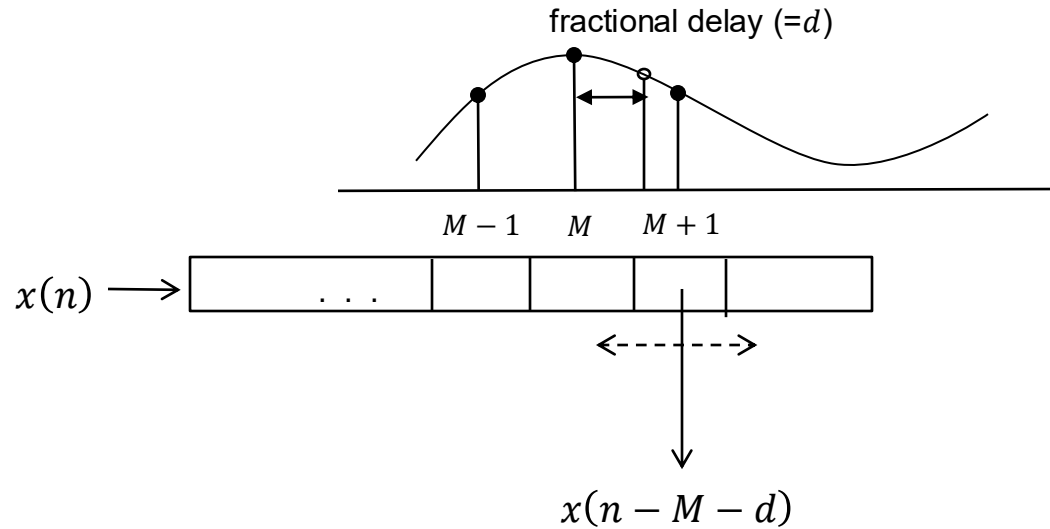

# Linear Interpolation

- The output is delayed approximately by  $d$ 
  - The phase delay in the low frequency range is close to the fractional delay  $d$
  - The output is attenuated in the high frequency range
  - Useful in “random access mode” (no recursion)

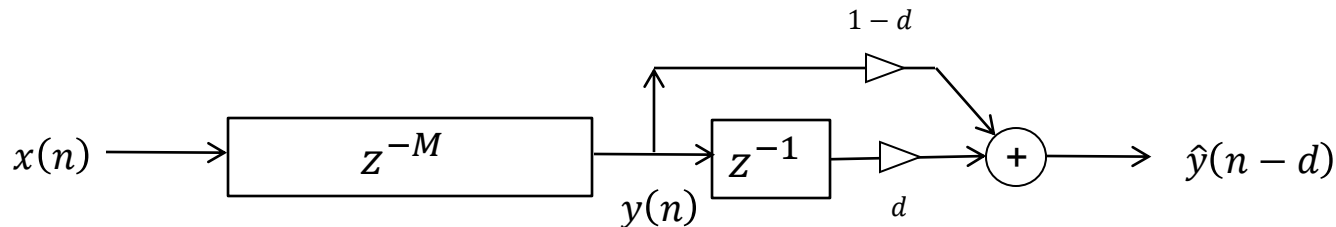

$$\hat{y}(n-d) = (1-d) \cdot y(n) + d \cdot y(n-1)$$

# Delay Effect

- Generate repetitive loop delay
  - Parameters
    - Feedback gain, delay length
  - Ping-pong delay: cross feedback between left and right channels in stereo
  - The delay length is often synchronized with music tempo

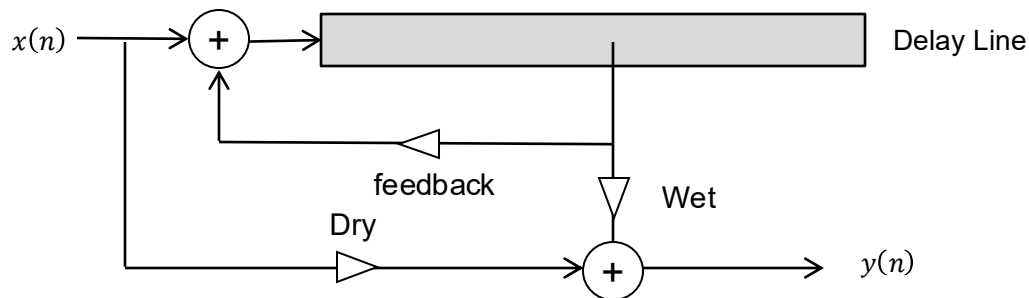

# Chorus Effect

- Gives the illusion of multiple voices playing in unison
  - By summing detuned copies of the input
  - Low frequency oscillators (LFOs) are used to modulate the position of output taps
    - This causes pitch-shift

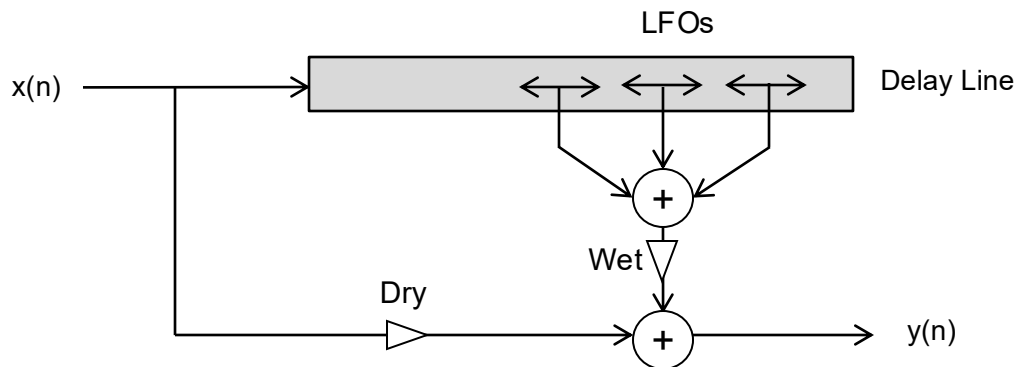

# Flanger Effect

- Emulated by summing one static tap and variable tap in the delay line
  - “Rocket sound”
  - Feed-forward comb filter where harmonic notches vary over frequency.
  - LFO is often synchronized with music tempo

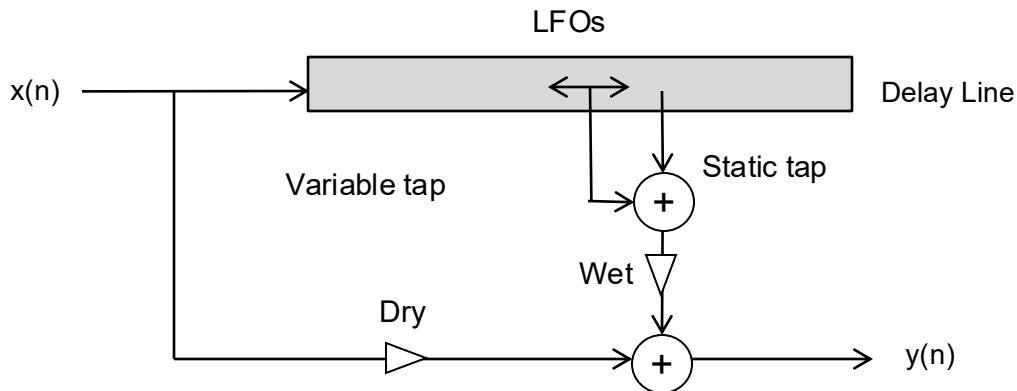

# Tape Delay Effect

- Model the warm and echo tone of tape delay effect
  - Roland space echo RE-201
    - Three play heads, bass/treble EQ and spring reverb
    - <http://www.roland.co.uk/blog/demystifying-magic-tape-echo/>
    - <https://www.youtube.com/watch?v=y3Whi-g-0A0>
  - Other models
    - <https://www.youtube.com/watch?v=b8DdHDRrBps>

# Loop Station

- Record and play musical tracks in a layer-by-layer manner with repetitions
  - 4 bar or 8-bar loop
- Examples
  - <https://www.youtube.com/watch?v=f0qR84PtctA>
  - <https://www.youtube.com/watch?v=02iGwll-qig>
  - <https://www.youtube.com/watch?v=r46LmtitZ7A>



# Reverberation

- Acoustic phenomenon when a sound source is played in a room
  - Thousands of echoes are reflected against wall, ceiling and floors
  - The patterns are determined by the volume and geometry of the room and materials on the surfaces
  - We can recognize the geometry and composition of the room from the sound
  - They provide different (often better) feelings of the sound

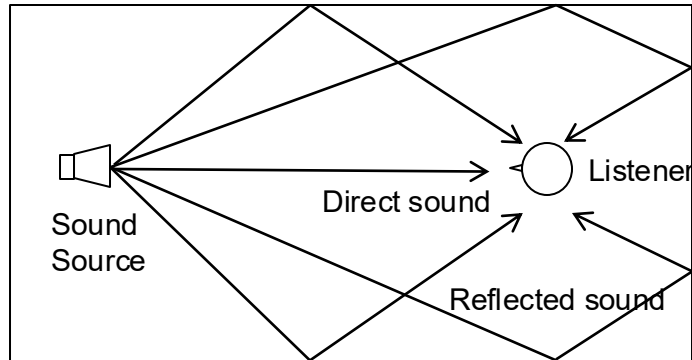

# Room Impulse Response

- Room reverberation is characterized by its impulse response (IR)
- The room IR is composed of three parts
  - Direct path
  - Early reflections: convey a sense of the room geometry and size
  - Late-field reverberation: high echo density like noise, determined by room size and materials
- RT60

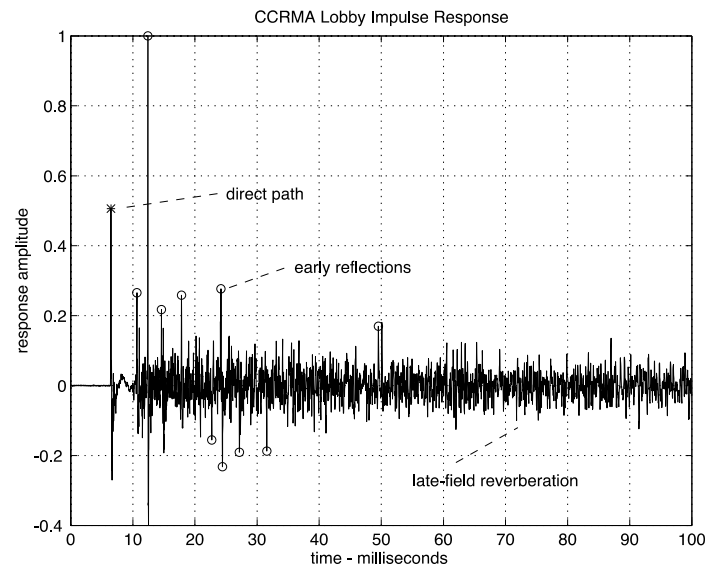

# Room Impulse Response

- Energy Envelope and Spectrogram

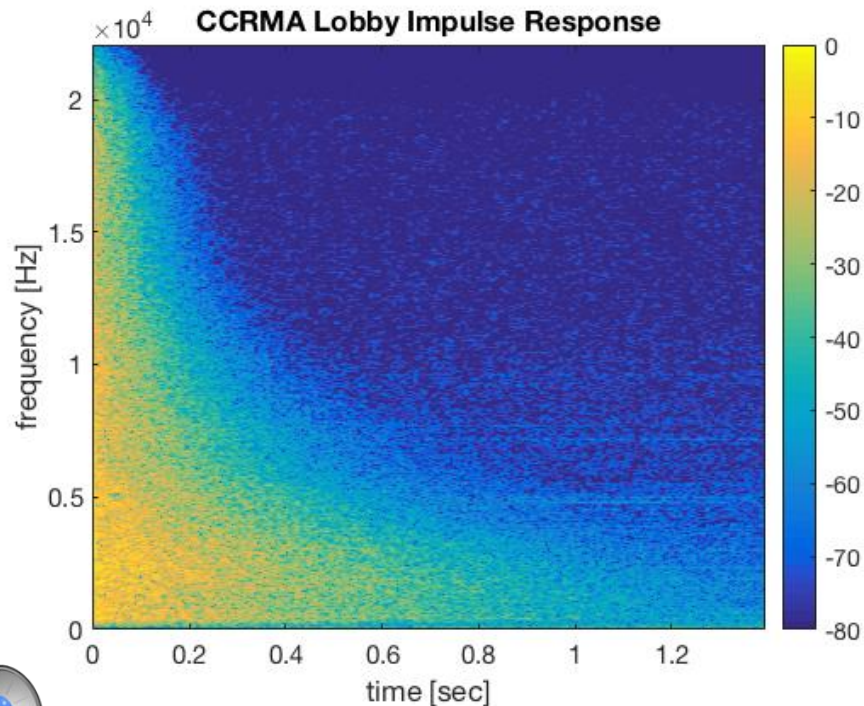
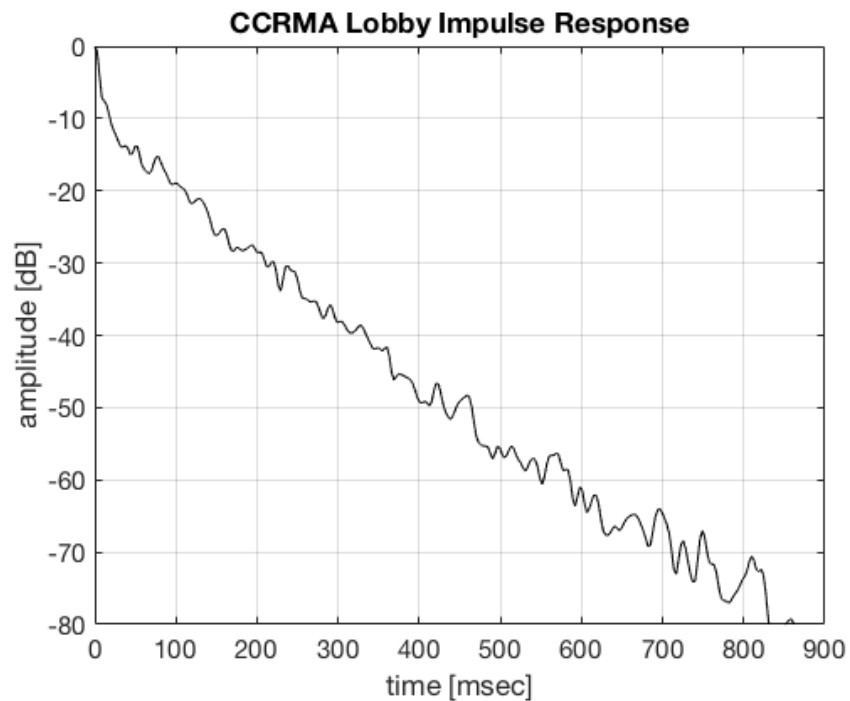

# Artificial Reverberation

- Convolution reverb
  - Measure the impulse response of a room
  - Convolve input with the measured IR
- Mechanical reverb
  - Use metal plate and spring
  - EMT140 Plate Reverb: <https://www.youtube.com/watch?v=HEmJpxCvp9M>
- Delay-based reverb
  - Early reflections: feed-forward delayline
  - Late-field reverb: allpass/comb filter, feedback delay networks (FDN)
  - “Programmable” reverberation



# Delay-based Reverb

- Schroeder model
  - Cascade of allpass-comb filters
  - Mutually prime number for delay lengths

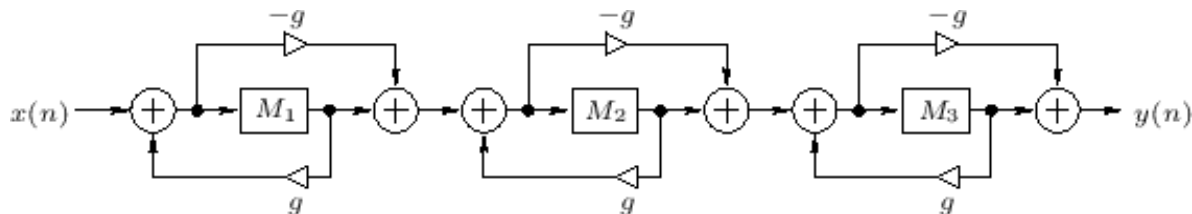

- Variations

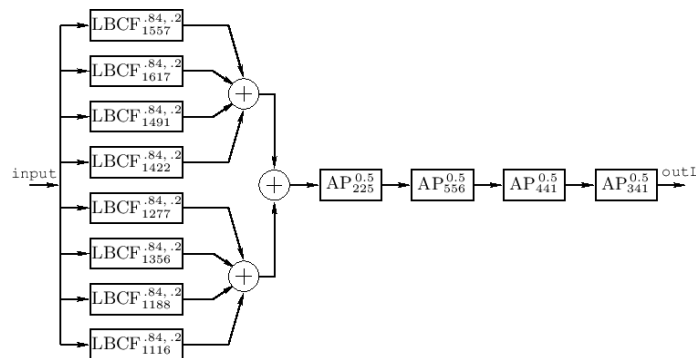
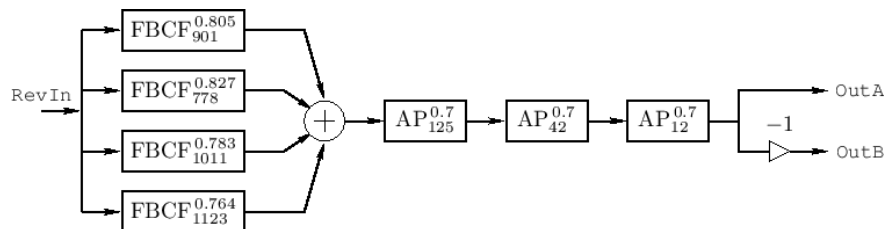

# Delay-based Reverb

- Feedback Delay Networks
  - Mixing matrix creates “good spreading” of delayed outputs
    - Chosen to be orthonormal (unitary matrix)
  - The lengths of delaylines are chosen to be mutually prime number
  - Should generate a white noise in lossless mode
  - T60 is controlled by the loop gains

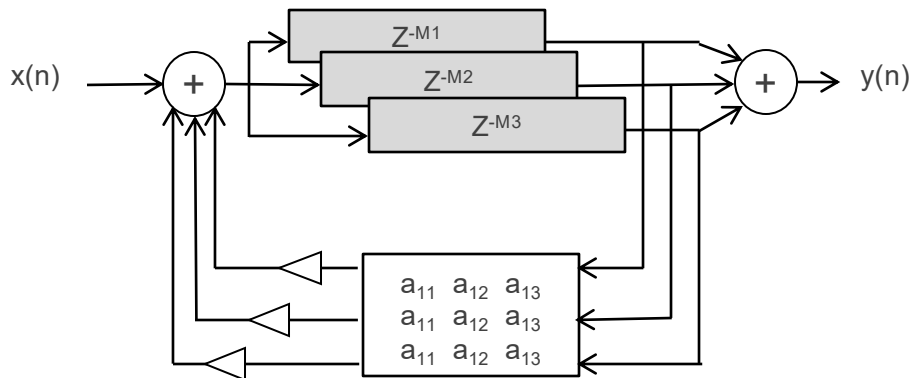

Feedback Delay Networks

# Measuring Impulse Response

- Measurement Model
  - Assume the system as linear time-invariant
  - Use a test signal and the output to derive the impulse response

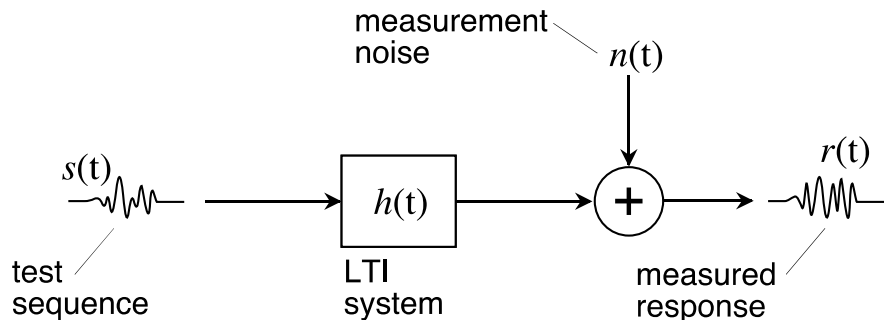

$$r(t) = \delta(t) * h(t) + n(t)$$

$$r(t) \rightarrow \hat{h}(t)$$

- Using a sine sweep: based on the convolution theorem

$$\hat{h}(t) = \text{FFT}^{-1} \left\{ \frac{\text{FFT} \{r(t)\}}{\text{FFT} \{s(t)\} + \varepsilon(f)} \right\}$$

# Measuring Room IRs

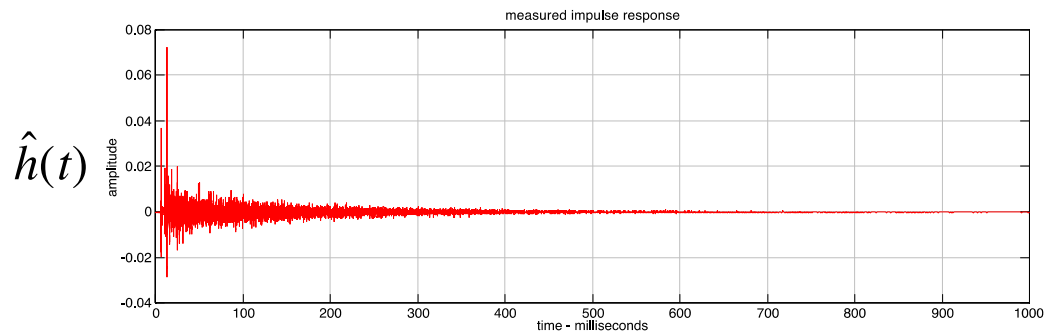
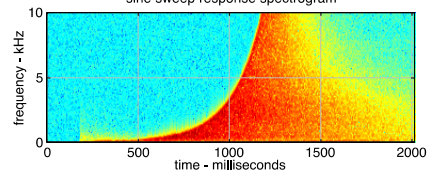
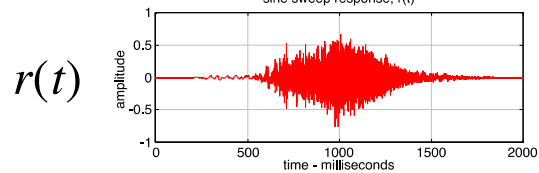
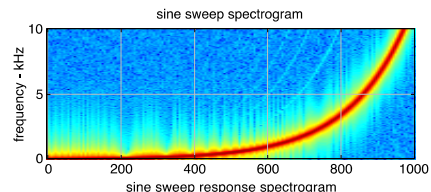
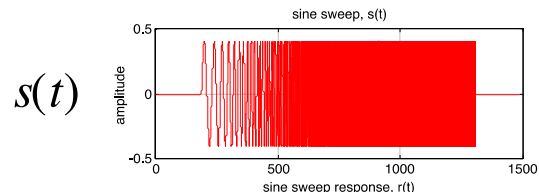

( J. Abel )

# Room IR datasets

- Open AIR
  - <http://www.openairlib.net/>
- Aachen Impulse Response Database
  - <http://www.iks.rwth-aachen.de/en/research/tools-downloads/databases/aachen-impulse-response-database/>

# References

- Reverberation using Feedback Delay Network
  - [https://ccrma.stanford.edu/~jos/pasp/FDN\\_Reverberation.html](https://ccrma.stanford.edu/~jos/pasp/FDN_Reverberation.html)
- Impulse Response Measurement
  - <http://pcfarina.eng.unipr.it/Public/Papers/226-AES122.pdf>

# Digital Waveguides

- Waveguide is a structure that guides waves such that the travelling is restricted to 1-D or 2-D
  - 1-D waveguide (string, pipe), 2-D waveguide (membrane, bar)
- Digital waveguides (J.O. Smith, 1992)
  - Spatially sampling the waveguide: implemented with **delay lines**

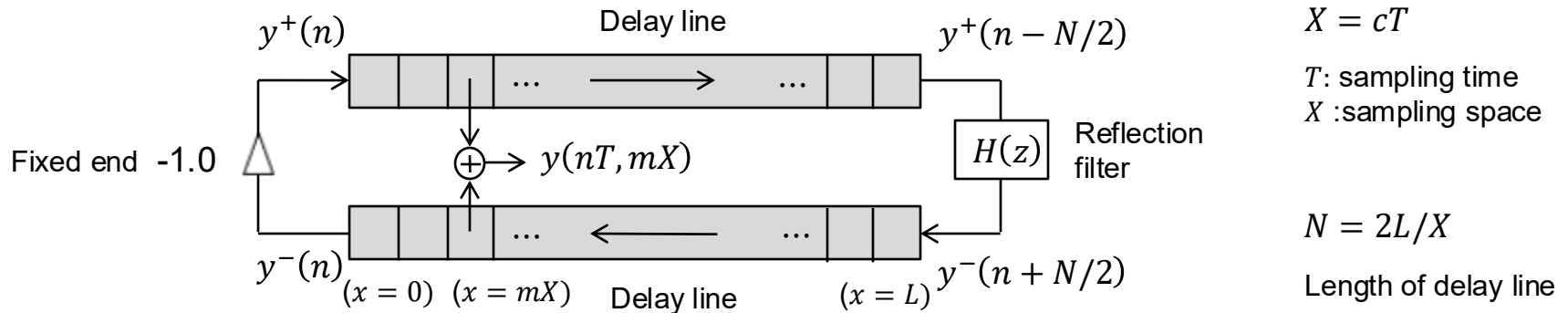

# Digital Waveguides

- More complete digital waveguide models simulate the physics in the entire instrument
  - Input: reed, bowing
  - Output: body filter

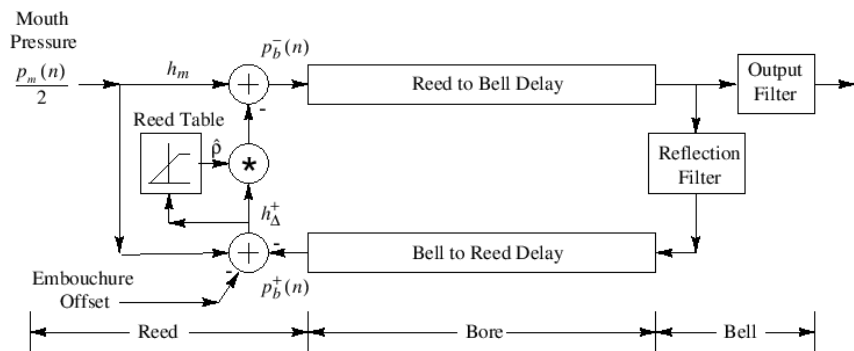

Single-reed Woodwind (e.g. clarinet)

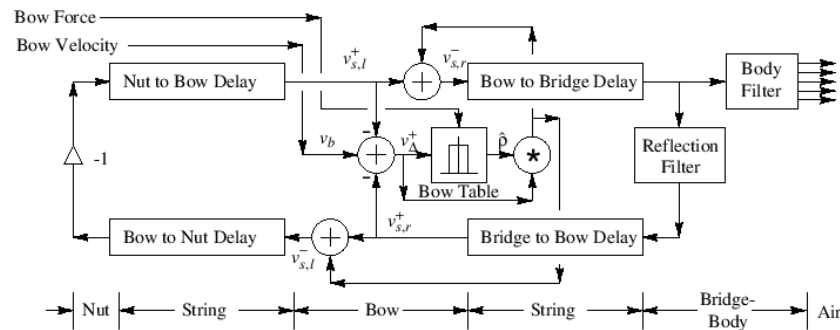

Bowed String

# Karplus-Strong Plucked String

- A special case of the digital waveguide model (1983)
  - A predecessor of the digital waveguide model
  - The single delay line implements the traveling wave
  - The lowpass filter works as a frequency-dependent damping filter
  - The noise burst provides a string excitation

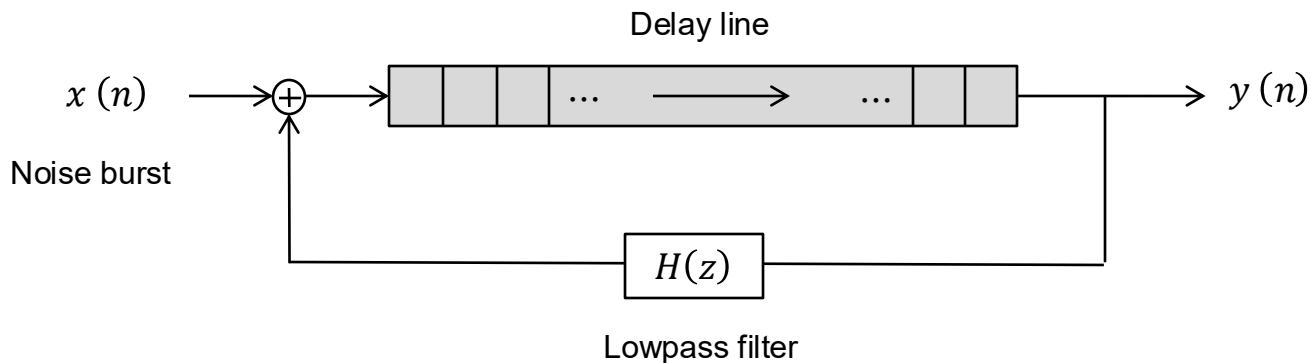

# Physical Modeling Examples

- Sound examples
  - [https://ccrma.stanford.edu/~jos/pasp/Sound\\_Examples.html](https://ccrma.stanford.edu/~jos/pasp/Sound_Examples.html)
- Interactive waveguide synthesis
  - <https://www.osar.fr/notes/waveguides/>